



SPECIFICATION

宏致電子股份有限公司

桃園縣中壢市東園路13號

No.13, Dongyuan Rd., Jhongli City,

Taoyuan County 320, Taiwan (R.O.C.)

TEL: +886-3-463-2808

FAX: +886-3-463-1800

SPEC. NO.: PS-51422-Txxx-xxx REVISION: A

PRODUCT NAME: 250 Series Crimping Terminal

PRODUCT NO: 51422

PREPARED: Liang,lin ji DATE: 2020/06/01	CHECKED: Lu Jing Quan DATE: 2020/06/01	APPROVED: hsieh fu yu DATE: 2020/06/01
--	---	---



TITLE: 250 Series Crimping Terminal

RELEASE DATE: 2020/06/01

REVISION: A

ECN No: ECN-2006035

PAGE: **2** OF **14**

1	REVISION HISTORY	3
2	SCOPE	4
3	APPLICABLE DOCUMENTS	4
4	REQUIREMENTS	4
5	PERFORMANCE.....	5
6	PRODUCT QUALIFICATION AND TEST SEQUENCE.....	8
7	MATING / UNMATING FORCE	9
8	ANATOMY OF CRIMPING TERMINAL.....	9
9	APPLICABLE WIRES: UL10987 ETFE WIRE	9
10	CRIMPING CONDITION.....	10
11	CRIMP HEIGHT MEASUREMENT	11
12	PULL FORCE OF CRIMPING SECTION MEASUREMENT	12
13	STANDARD INSULATION CRIMPING	12
14	CONDUCTORS CRIMPING CONDITION.....	13
15	CRIMPING REQUIREMENT	14



Aces P/N: **51422-TXXX-XXX**

TITLE: 250 Series Crimping Terminal

RELEASE DATE: 2020/06/01

REVISION: A

ECN No: ECN-2006035

PAGE: **3** OF **14**

1 Revision History

Rev.	ECN #	Revision Description	Prepared	Date
A	ECN-2006035	FOR APD1070329 NEW	Liang lin ji	2020/06/01

TITLE: 250 Series Crimping Terminal

RELEASE DATE: 2020/06/01

REVISION: A

ECN No: ECN-2006035

PAGE: **4** OF **14**

2 SCOPE

This specification covers performance, tests and quality requirements for **250 Series Crimping Terminal** . (Lead free product)

ACES P/N : 51422-Txxx Crimping Terminal

3 APPLICABLE DOCUMENTS

EIA-364 ELECTRONICS INDUSTRIES ASSOCIATION

4 REQUIREMENTS

4.1 Design and Construction

- 4.1.1 Product shall be of design, construction and physical dimensions specified on applicable product drawing.
- 4.1.2 All materials conform to R.o.H.S. and the standard depends on TQ-WI-140101.

4.2 Materials and Finish

- 4.2.1 Crimping Terminal: High performance copper alloy (**BRASS**)
Finish: (a) Area: **Matte Tin Plating over all.**
(b) Under plate: **Nickel-plated all over**

4.3 Ratings

- 4.3.1 Voltage Rating: **250 Volts (AC(rms) /DC)**
- 4.3.2 Current Rating:
 - AWG#10: 24.0A (AC(rms) /DC)**
 - AWG#12: 20.0A (AC(rms) /DC)**
 - AWG#14: 15.0A (AC(rms) /DC)**

- 4.3.3 Operating Temperature : **-40°C to +105°C**

TITLE: 250 Series Crimping Terminal

RELEASE DATE: 2020/06/01

REVISION: A

ECN No: ECN-2006035

PAGE: **5** OF **14**

5 Performance

5.1. Test Requirements and Procedures Summary

Item	Requirement	Standard
Examination of Product	Product shall meet requirements of applicable product drawing and specification.	Visual, dimensional and functional per applicable quality inspection plan.
ELECTRICAL		
Item	Requirement	Standard
Low Level Contact Resistance	55 m Ω Max.(initial)per contact ΔR 20 m Ω Max.	Mate connectors, measure by dry circuit, 20mV Max., 100mA Max. (EIA-364-23)
Insulation Resistance	500 M Ω Min.	Unmated connectors, apply 500 V DC between adjacent terminals. (EIA-364-21)
Dielectric Withstanding Voltage	No discharge, flashover or breakdown. Current leakage: 1 mA max.	300V AC Min. at sea level for 1 minute. Test between adjacent contacts of unmated connectors. (EIA-364-20)
Temperature rise	30°C Max. Change allowed	Mate connector: measure the temperature rise at rated current until temperature stable. The ambient condition is still air at 25°C (EIA-364-70,METHOD1,CONDITION1)

MECHANICAL		
Item	Requirement	Standard
Durability	10 cycles.	The sample should be mounted in the tester and fully mated and unmated the number of cycles specified at the rate of 25.4 ± 3mm/min.
Mating / Unmating Forces	Please see item7	Operation Speed : 25.4 ± 3 mm/minute.. Measure the force required to mate/Unmate connector. (EIA-364-13)
Crimping Pull Out Force	AWG10# 7Kgf Min. AWG12# 6Kgf Min. AWG14# 6Kgf Min.	Operation Speed : 25.4 ± 3 mm/minute. Fix the crimped terminal, apply axial pull out force on the wire.

TITLE: 250 Series Crimping Terminal

RELEASE DATE: 2020/06/01

REVISION: A

ECN No: ECN-2006035

PAGE: **6** OF **14**

Vibration	1 μ s Max.	The electrical load condition shall be 100 mA maximum for all contacts. Subject to a simple harmonic motion having amplitude of 0.76mm (1.52mm maximum total excursion) in frequency between the limits of 10 and 55 Hz . The entire frequency range, from 10 to 55 Hz and return to 10 Hz , shall be traversed in approximately 1 minute. This motion shall be applied for 2 hours in each of three mutually perpendicular directions. (EIA-364-28 Condition I)
Shock (Mechanical)	1 μ s Max.	Subject mated connectors to 50 G's (peak value) half-sine shock pulses of 11 milliseconds duration. Three shocks in each direction shall be applied along the three mutually perpendicular axes of the test specimen (18 shocks). The electrical load condition shall be 100mA maximum for all contacts. (EIA-364-27, test condition A)

ENVIRONMENTAL

Item	Requirement	Standard
Thermal Shock	See Product Qualification and Test Sequence Group 4	Mate module and subject to follow condition for 5 cycles. 1 cycles: -55 +0/-3 °C , 30 minutes +85 +3/-0 °C , 30 minutes (EIA-364-32, test condition I)
Humidity	See Product Qualification and Test Sequence Group 4	Mated Connector 40°C , 90~95% RH, 96 hours. (EIA-364-31, Condition A, Method II)
Temperature life	See Product Qualification and Test Sequence Group 5	Subject mated connectors to temperature life at 85°C fo 96 hours . (EIA-364-17, Test condition A)
Salt Spray (Only For Gold Plating)	See Product Qualification and Test Sequence Group 6	Subject mated/unmated connectors to 5% salt-solution concentration, 35°C (I) Gold flash for 8 hours (EIA-364-26)

Note. Flowing Mixed Gas shall be conducted by customer request.

TITLE: 250 Series Crimping Terminal

RELEASE DATE: 2020/06/01

REVISION: A

ECN No: ECN-2006035

PAGE: **7** OF **14**

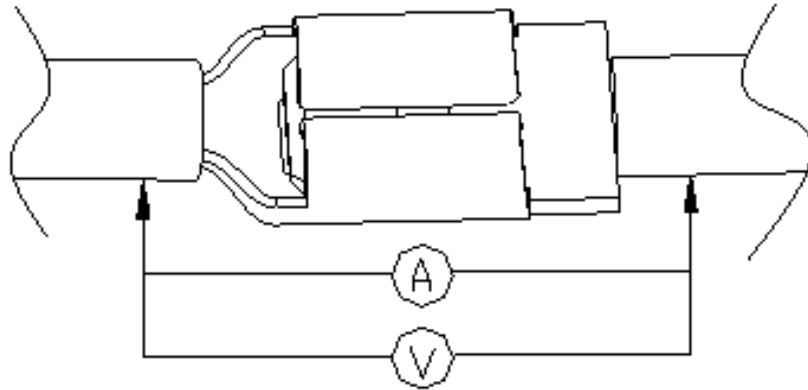

Contact Resistance Measuring Point

TITLE: 250 Series Crimping Terminal

RELEASE DATE: 2020/06/01

REVISION: A

ECN No: ECN-2006035

PAGE: **8** OF **14**

6 PRODUCT QUALIFICATION AND TEST SEQUENCE

Test or Examination	Test Group								
	1	2	3	4	5	6	7		
	Test Sequence								
Examination of Product				1、7	1、6	1、4			
Low Level Contact Resistance		1、5	1、4	2、10	2、9	2、5			
Insulation Resistance				3、9	3、8				
Dielectric Withstanding Voltage				4、8	4、7				
Temperature Rise	1								
Mating / Unmating Force		2、4							
Durability		3							
Vibration			2						
Shock (Mechanical)			3						
Thermal Shock				5					
Humidity				6					
Temperature Life					5				
Salt Spray						3			
Crimping Pull Out Force							1		
Sample Size	2	4	4	4	4	4	4		

TITLE: 250 Series Crimping Terminal

RELEASE DATE: 2020/06/01

REVISION: A

ECN No: ECN-2006035

PAGE: **9** OF **14**

7 Mating / Unmating Force

Initial		After 10 th Cycle
Insertion Force (Max.)	Withdrawal Force (Min.)	Withdrawal Force (Min)
7.75Kgf	2.0Kgf	1.8Kgf

8 ANATOMY OF CRIMPING TERMINAL :

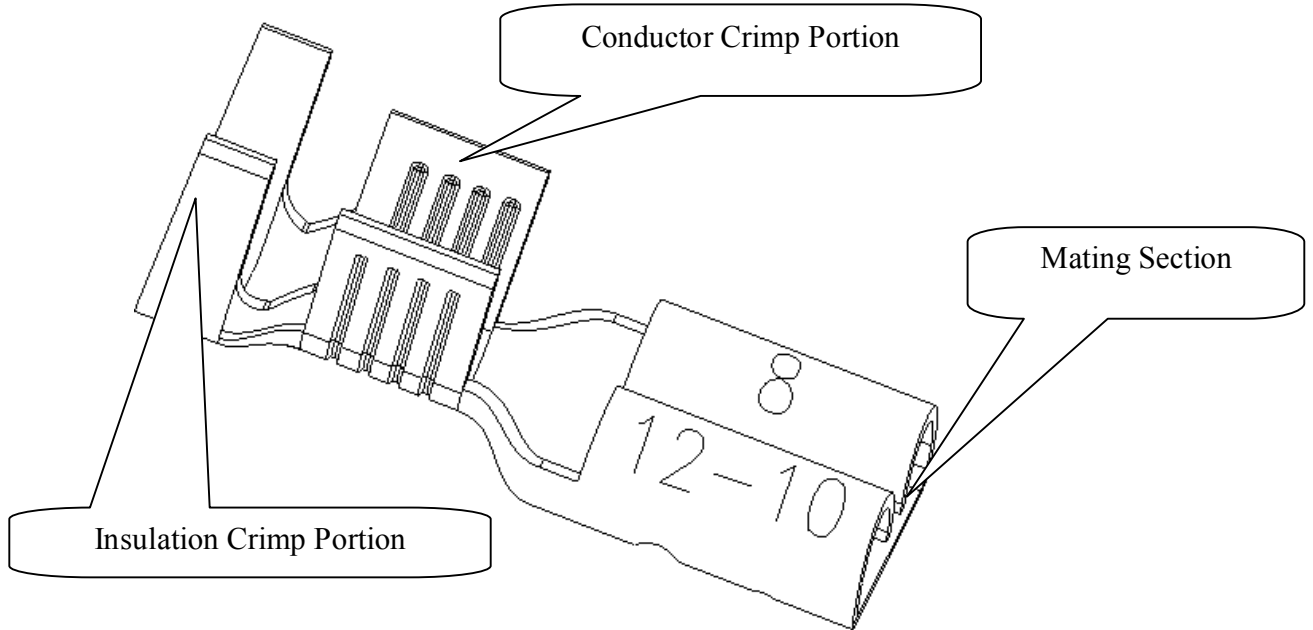

9 Applicable Wires :

UL1015, UL3321, UL10070, UL10198
10AWG, 12AWG, 14AWG

AWG Size : AWG10~14 #

Insulation OD : Φ 5.2~3.4mm

TITLE: 250 Series Crimping Terminal

RELEASE DATE: 2020/06/01

REVISION: A

ECN No: ECN-2006035

PAGE: **10** OF **14**

10 Crimping Condition :

鉚線條件表 CRIMPING CONDITION							
Part Number	Wire Specification			Crimp Height (mm)		Crimp Width (mm)	
	UL Style (REF.)	AWG Size	Insulation OD(mm)	Conductor A	Insulation B	Conductor W1	Insulation W2
51422-Txxx-xxx	UL1015	10	5.2Max	2.85~3.20	4.6~5.2	3.7 Max.	5.45Max.
51422-Txxx-xxx	UL1015	12	4.2Max	2.45~2.75	4.1~4.4	3.6 Max.	5.30Max.
51422-Txxx-xxx	UL1015	14	3.6Max	2.10~2.50	3.9~4.3	3.4Max.	5.15Max.

Note:

- 1、W1(Conductor Crimping Width) : W1
- 2、W2(Insulator Crimping Width) : W2
- 3、A (conductor Crimping height) : A
- 4、B (Insulator Crimping height) : B
- 5、Strip Length : 6.3~6.8mm(Ref.)

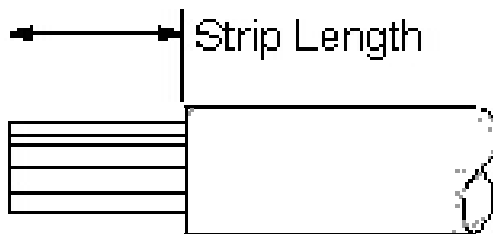
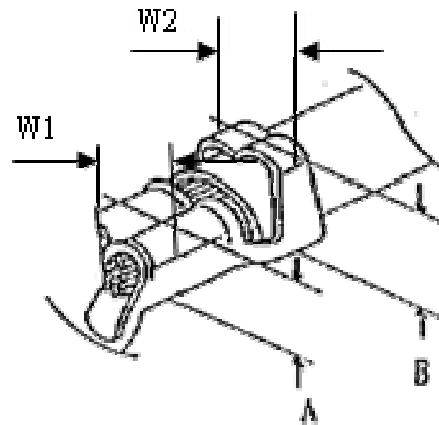

TITLE: 250 Series Crimping Terminal

RELEASE DATE: 2020/06/01

REVISION: A

ECN No: ECN-2006035

PAGE: **11** OF **14**

11 Crimping Height Measurement :

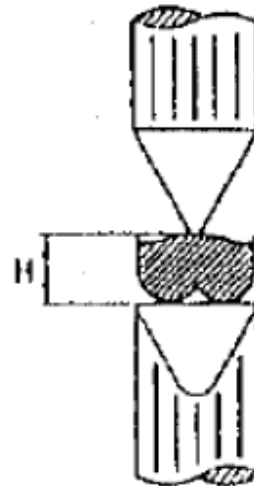
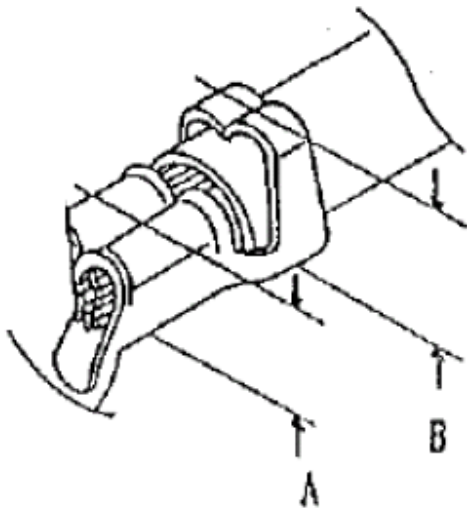
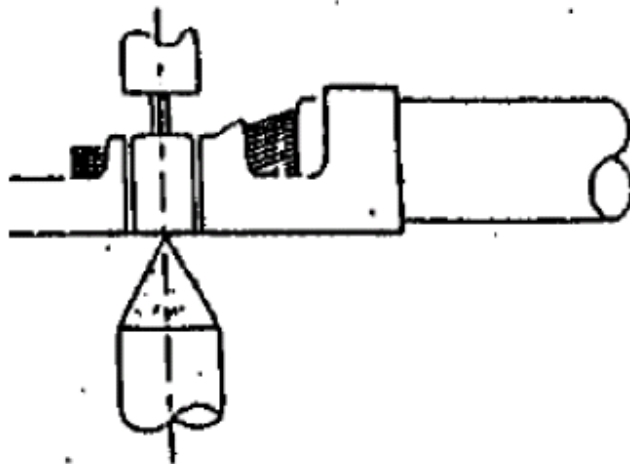
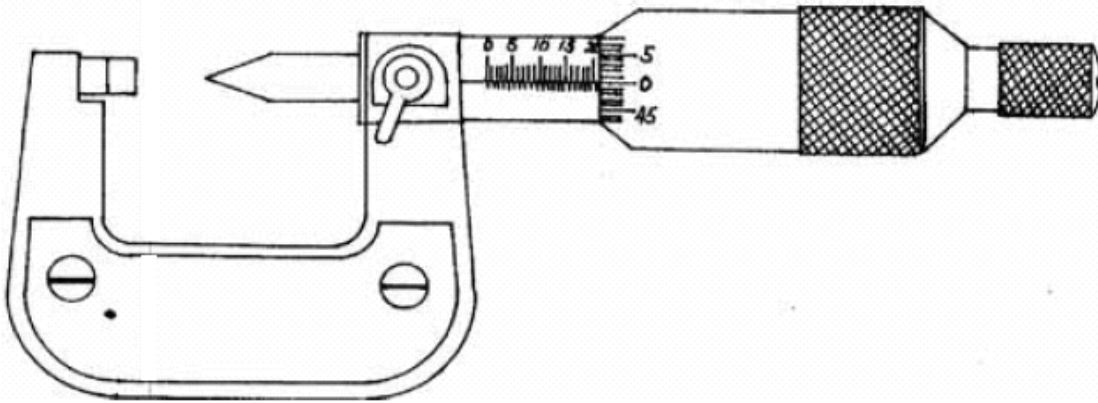

TITLE: 250 Series Crimping Terminal

RELEASE DATE: 2020/06/01

REVISION: A

ECN No: ECN-2006035

PAGE: **12** OF **14**

12 Pull Force of Crimping Section Measurement :



Before test samples, please measure crimp height and do not crimp insulation.

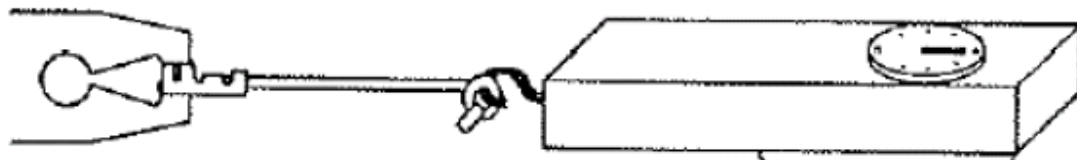

Pull Force of Crimp Section Measurement

13 Standard Insulation Crimping :

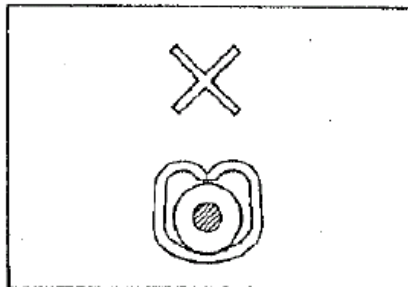

Not enough crimp

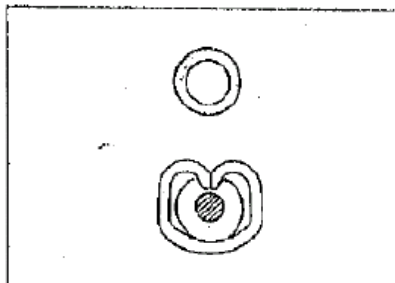

Good

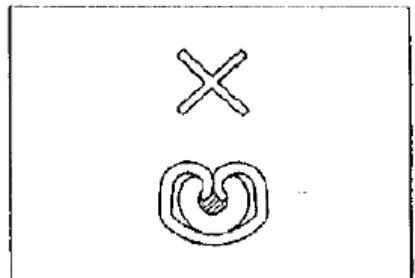

Crimp too much

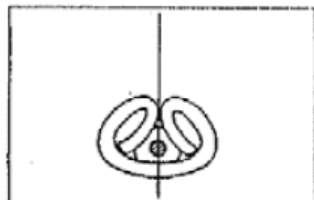

Good

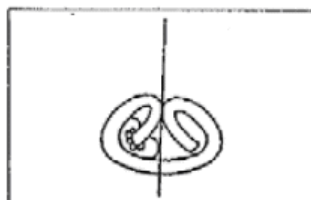

NG

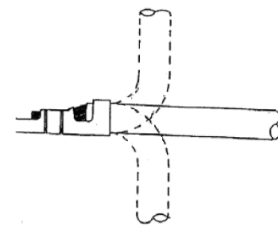

As following figure shown. It is no problem if wire bent up down 90 degrees 1 cycle and insulation position still in ideal position.

Insulation Crimp Condition

14 Conductors Crimping Condition :

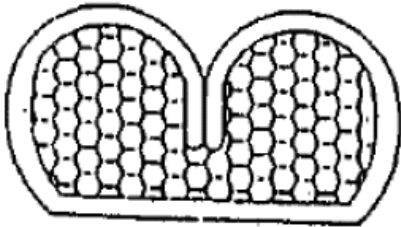

Good

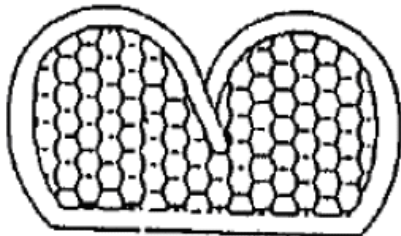

NG

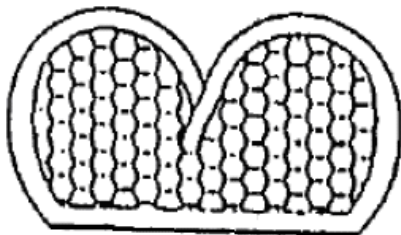

NG

Lower conduct
retension force



Good



NG

Large burr

15 Crimping Requirement :

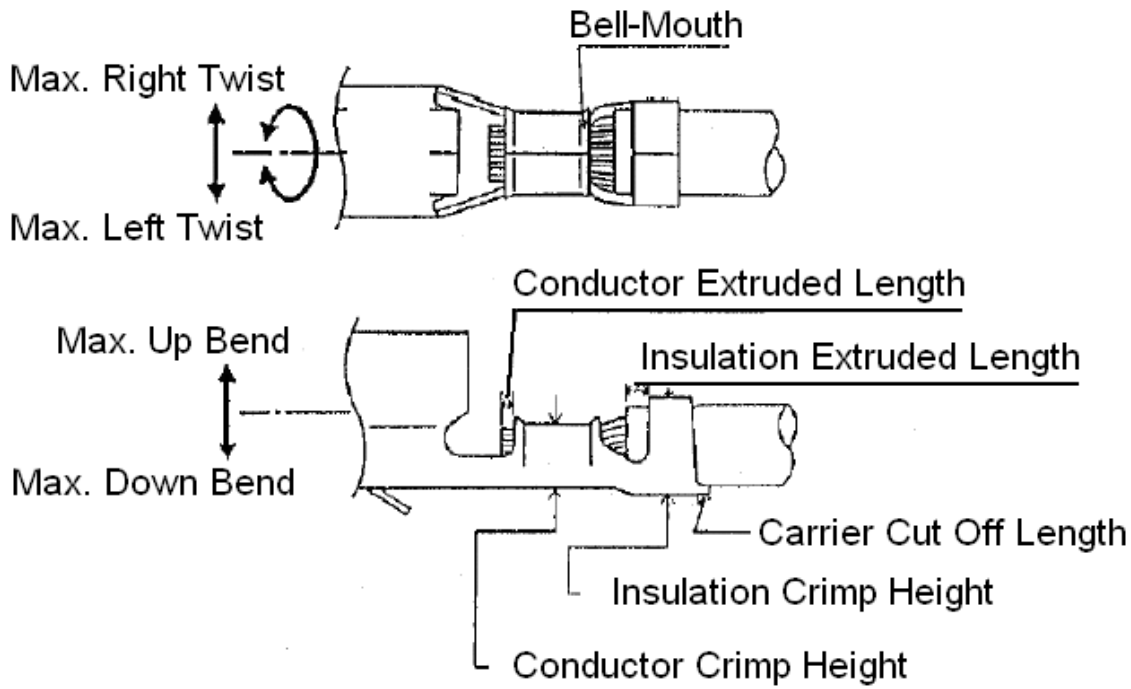

Item	Range (Ref.)
Max. Up Bend	6°
Max. Down Bend	6°
Max. Left Twist	5°
Max. Right Twist	5°
Bell-Mouth Length	0.1~0.3 mm
Carrier Cut Off Length	0~0.2mm
Conductor Extruded Length	0.05~0.3 mm